

Silicon Diode

BYV96D

800V/1.5A

DATASHEET

OEM – Philips

Source: Philips Databook 1999

Fast soft-recovery controlled avalanche rectifiers

BYV96 series

FEATURES

- Glass passivated
- High maximum operating temperature
- Low leakage current
- Excellent stability
- Guaranteed avalanche energy absorption capability
- Available in ammo-pack.

DESCRIPTION

Rugged glass package, using a high temperature alloyed construction. This package is hermetically sealed and fatigue free as coefficients of expansion of all used parts are matched.

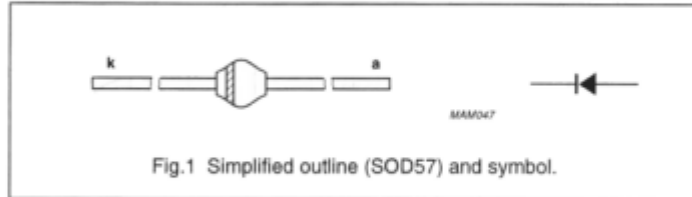

LIMITING VALUES

In accordance with the Absolute Maximum Rating System (IEC 134).

SYMBOL	PARAMETER	CONDITIONS	MIN.	MAX.	UNIT
V_{RRM}	repetitive peak reverse voltage	BYV96D	–	800	V
		BYV96E	–	1000	V
V_R	continuous reverse voltage	BYV96D	–	800	V
		BYV96E	–	1000	V
$I_{F(AV)}$	average forward current	$T_{ip} = 55\text{ °C}$; lead length = 10 mm see Fig 2; averaged over any 20 ms period; see also Fig 6	–	1.5	A
		$T_{amb} = 55\text{ °C}$; PCB mounting (see Fig.11); see Fig 3; averaged over any 20 ms period; see also Fig 6	–	0.8	A
I_{FRM}	repetitive peak forward current	$T_{ip} = 55\text{ °C}$; see Fig 4	–	17	A
		$T_{amb} = 55\text{ °C}$; see Fig 5	–	9	A
I_{FSM}	non-repetitive peak forward current	$t = 10\text{ ms}$ half sine wave; $T_j = T_{j\max}$ prior to surge; $V_R = V_{RRM\max}$	–	35	A
E_{RSM}	non-repetitive peak reverse avalanche energy	$L = 120\text{ mH}$; $T_j = T_{j\max}$ prior to surge; inductive load switched off	–	10	mJ
T_{stg}	storage temperature		–65	+175	°C
T_j	junction temperature	see Fig 7	–65	+175	°C

Fast soft-recovery
controlled avalanche rectifiers

BYV96 series

ELECTRICAL CHARACTERISTICS $T_J = 25\text{ °C}$ unless otherwise specified.

SYMBOL	PARAMETER	CONDITIONS	MIN.	TYP.	MAX.	UNIT
V_F	forward voltage	$I_F = 3\text{ A}$; $T_J = T_{J\text{max}}$; see Fig 8	–	–	1.35	V
		$I_F = 3\text{ A}$; see Fig 8	–	–	1.60	V
$V_{(BR)R}$	reverse avalanche breakdown voltage	$I_R = 0.1\text{ mA}$				
			BYV96D	900	–	–
	BYV96E	1100	–	–	V	
I_R	reverse current	$V_R = V_{RRM\text{max}}$; see Fig 9	–	–	1	μA
		$V_R = V_{RRM\text{max}}$; $T_J = 165\text{ °C}$; see Fig 9	–	–	150	μA
t_{rr}	reverse recovery time	when switched from $I_F = 0.5\text{ A}$ to $I_R = 1\text{ A}$; measured at $I_R = 0.25\text{ A}$; see Fig 12	–	–	300	ns
C_d	diode capacitance	$f = 1\text{ MHz}$; $V_R = 0\text{ V}$; see Fig 10	–	40	–	pF
$\left \frac{dI_R}{dt}\right $	maximum slope of reverse recovery current	when switched from $I_F = 1\text{ A}$ to $V_R \geq 30\text{ V}$ and $dI_F/dt = -1\text{ A}/\mu\text{s}$; see Fig.13	–	–	6	$\text{A}/\mu\text{s}$

THERMAL CHARACTERISTICS

SYMBOL	PARAMETER	CONDITIONS	VALUE	UNIT
$R_{th\ j\text{-tp}}$	thermal resistance from junction to tie-point	lead length = 10 mm	46	K/W
$R_{th\ j\text{-a}}$	thermal resistance from junction to ambient	note 1	100	K/W

Note

1. Device mounted on an epoxy-glass printed-circuit board, 1.5 mm thick; thickness of Cu-layer $\geq 40\ \mu\text{m}$, see Fig.11. For more information please refer to the 'General Part of Handbook SC01'

Fast soft-recovery
controlled avalanche rectifiers

BYV96 series

GRAPHICAL DATA

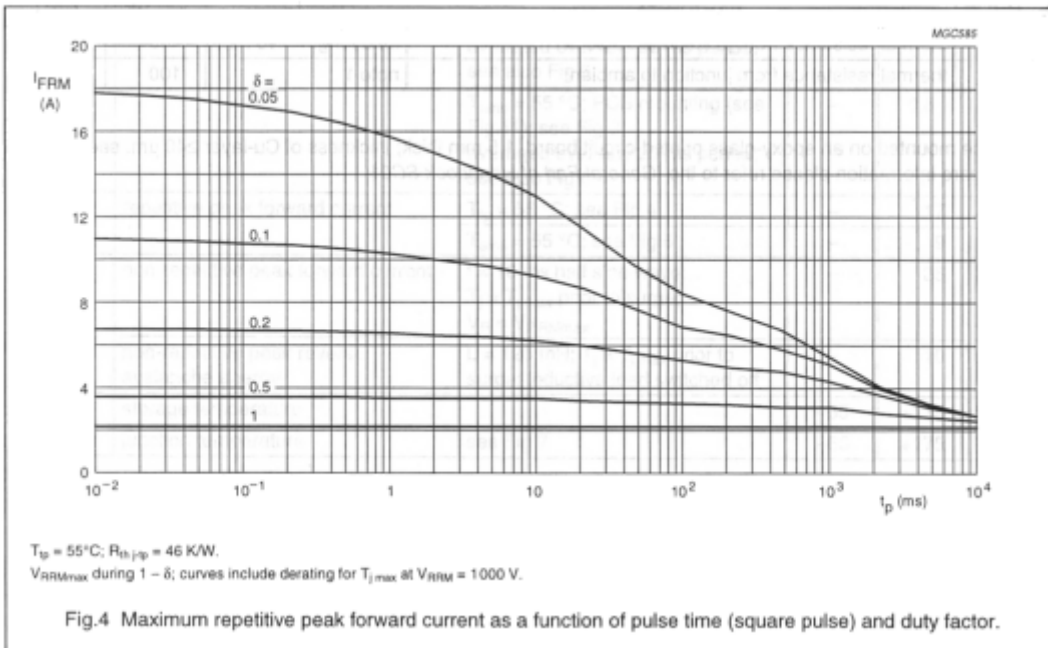
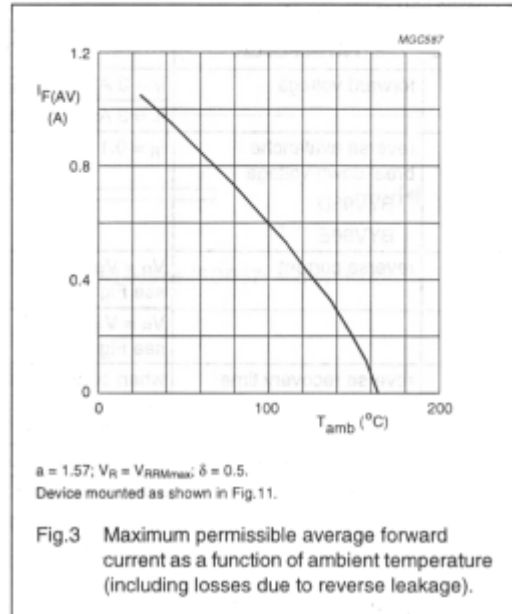
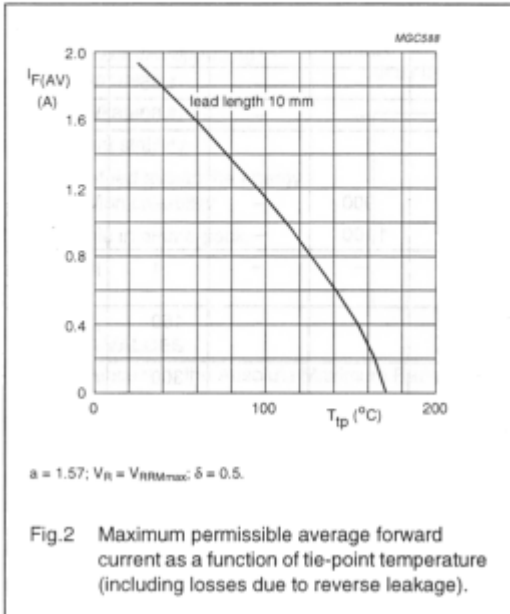

Fast soft-recovery
controlled avalanche rectifiers

BYV96 series

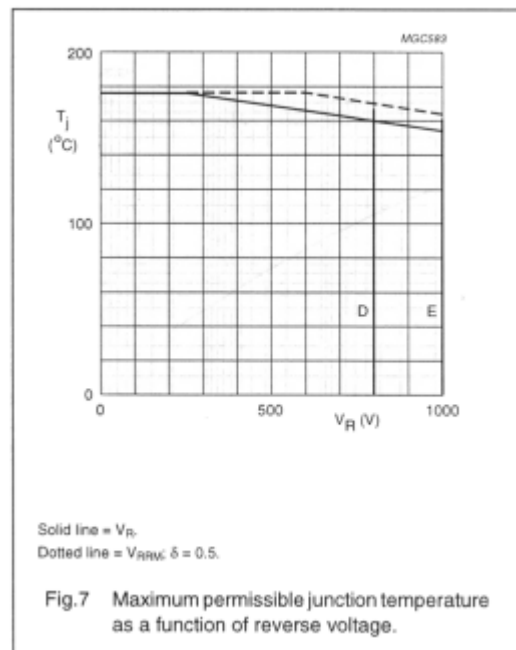
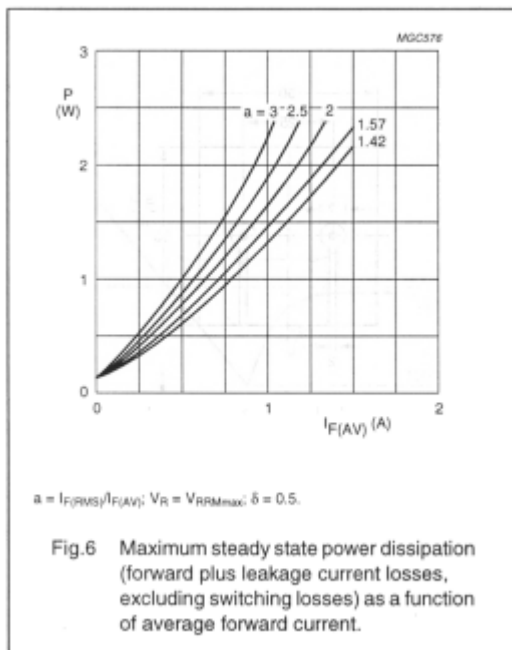
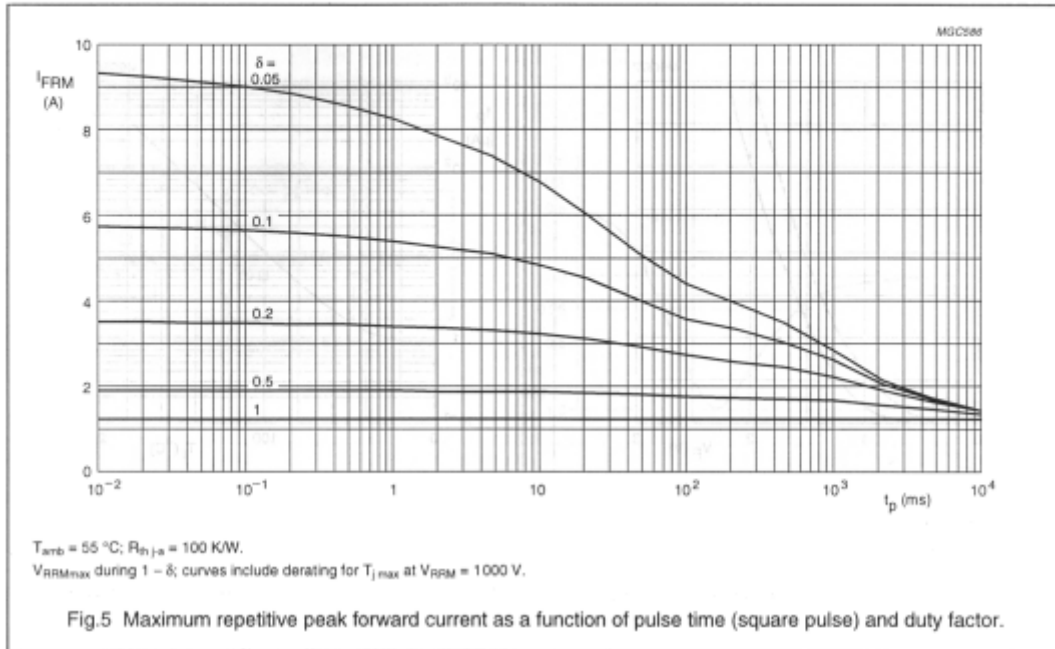

Fast soft-recovery
controlled avalanche rectifiers

BYV96 series

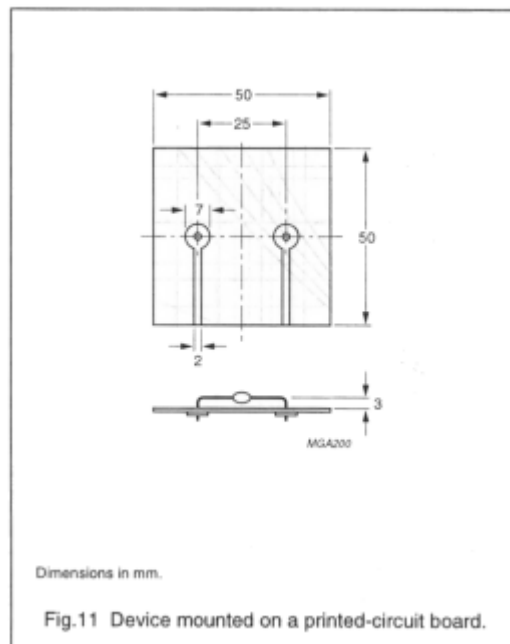
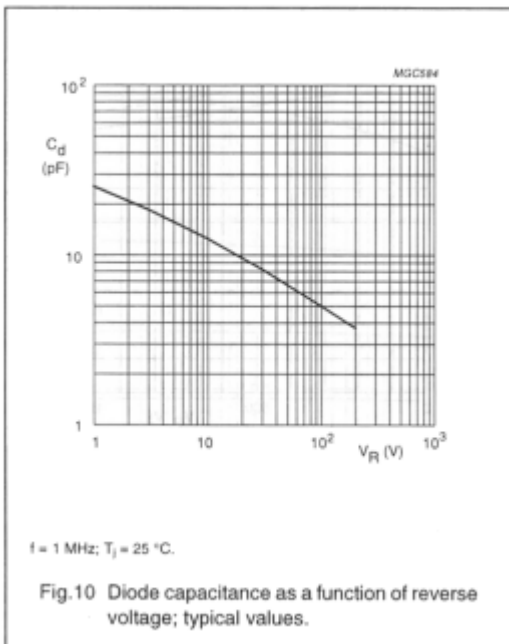
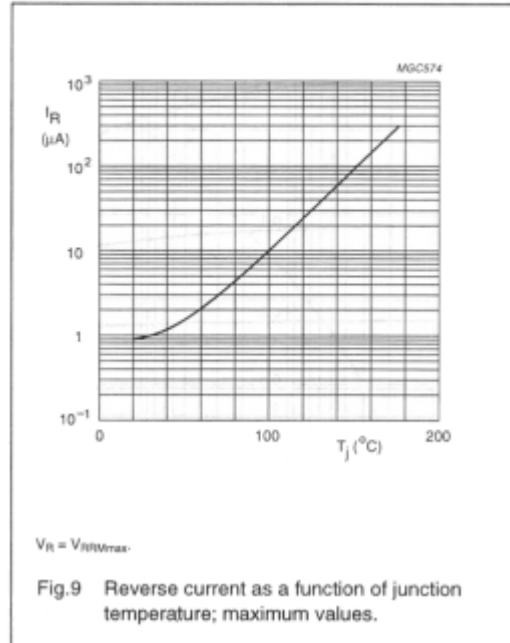
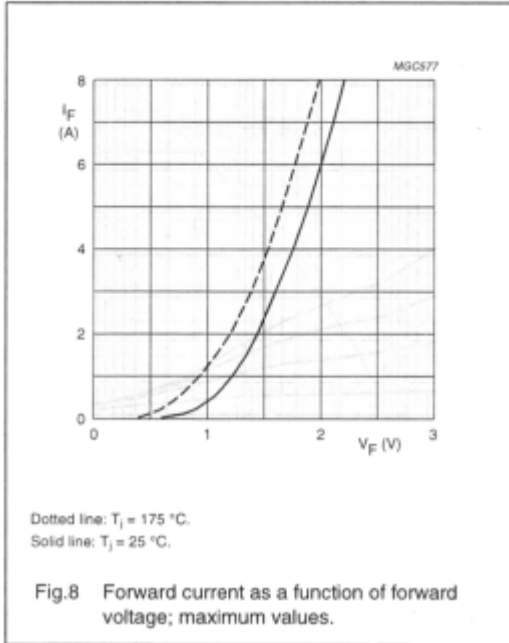

Fast soft-recovery
controlled avalanche rectifiers

BYV96 series

